



BRAKE DRUM MICROMETER

OPERATING INSTRUCTIONS WITH PARTS IDENTIFICATION -

NO. 8500
NO. 8500-50

AMMCO TOOLS, INC. / WACKER PARK / NORTH CHICAGO, ILLINOIS 60064 U.S.A. / (312) 689-1111
CABLE: AMMCO EXP / TELEX: 254795

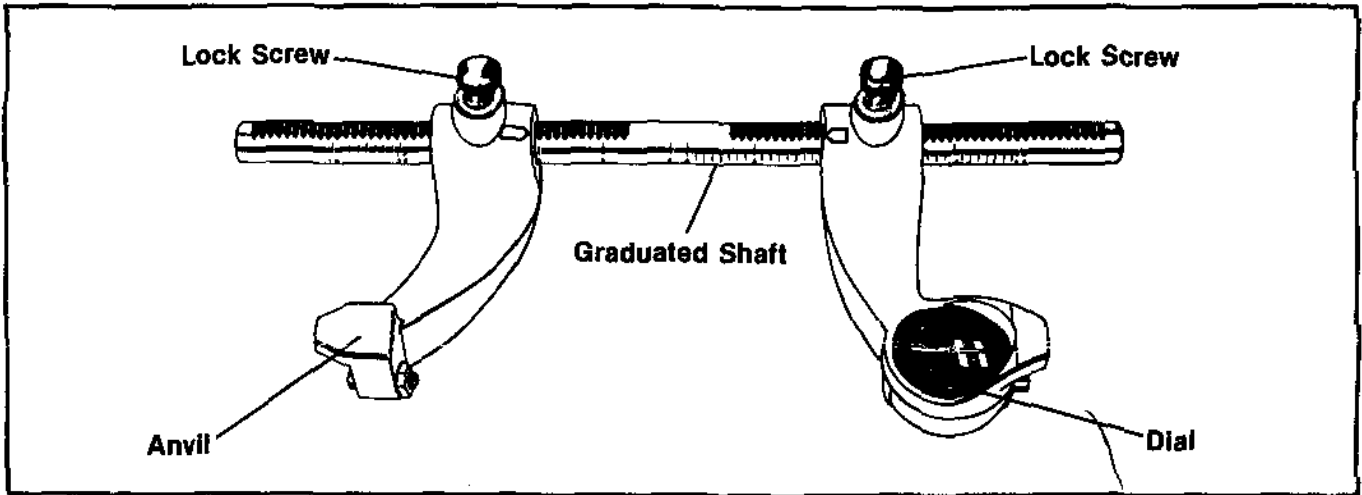

INCH — No. 8500

- **Drum Sizes:** 6" to 16-1/8" diameters
- **Scale Graduations:** .005" increments
- **Graduated Shaft:** divided in 1" and 1/8" increments for drum diameters
- **Optional Graduated Shaft:** 16" — 26"

METRIC — No. 8500-50

- **Drum Sizes:** 15 cm to 41 cm diameters
- **Scale Graduations:** .1 mm increments
- **Graduated Shaft:** divided in 1 cm and 2 mm increments for drum diameters
- **Optional Graduated Shaft:** 39 cm — 66 cm

MEASURING THE DRUM

1. Loosen the two knurled lock screws and move both the dial and the anvil along the shaft until the "whole" number of the drum diameter is visible at each arrow.

NOTE: The inch graduated shaft has identical scales front and back.

The metric graduated shaft has "even" numbers on one side and "odd" numbers on the other side.

2. Place the micrometer inside the drum and across the greatest diameter to be measured. The anvil is held steady and the dial is moved back and forth against the braking surface of the drum to obtain the highest reading, Fig. 1.

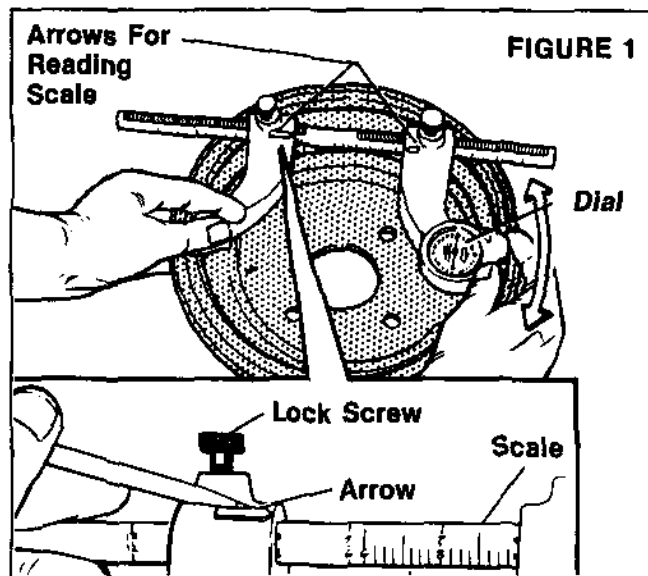

DRUM CONDITION

Drums should always be carefully inspected for cracks, worn or loose bearing races, scoring, heat checks, taper, bell-mouth, and out-of-roundness. Drum out-of-round conditions are checked by taking micrometer readings at two or more positions around the drum.

Scoring, out-of-roundness, bell-mouth, and taper should be corrected by machining on your AMMCO Brake Lathe. Correcting most of the above conditions will require cutting material from the drum wall. If the drum diameter after machining is larger than the manufacturer's specified rebores limit it must be replaced.

Drums that are too thin are apt to be weak and springy, and will not dissipate heat well which results in loss of braking power. **DEFECTIVE DRUMS SHOULD BE SCRAPPED.**

CALIBRATION

The micrometer is calibrated at the factory. Calibration can be checked by using a No. 9582 Checking Gauge, Fig. 2, or a standard outside micrometer. If recalibration is necessary, loosen the Jam Nut (31) and adjust the set screw (30) until the correct reading is obtained. Retighten the jam nut while holding the set screw stationary.

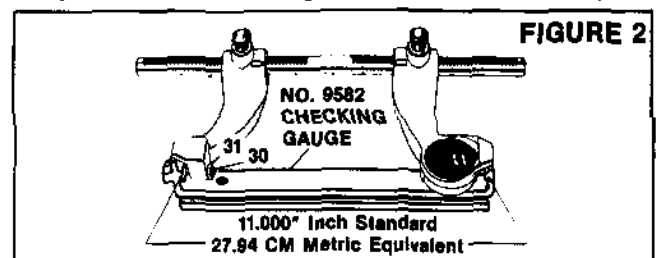

INCH (Examples For Reading The Inch Micrometer)

**11.000 in.
Diameter**

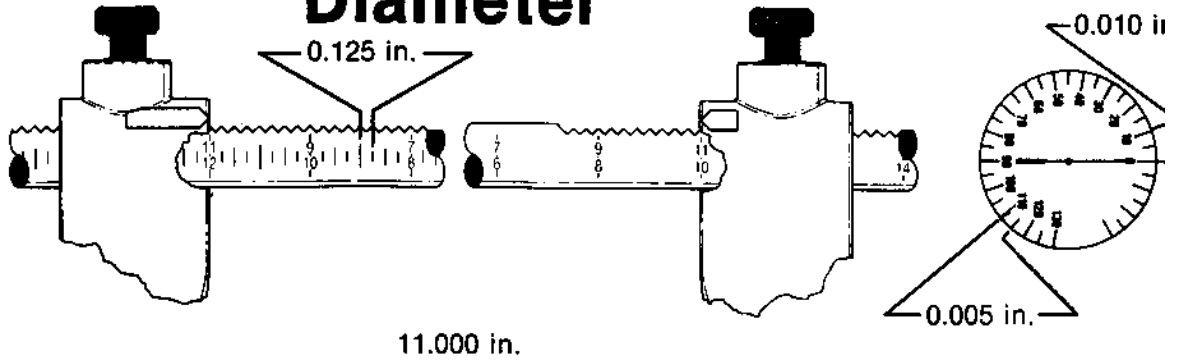

**11.375 in.
Diameter**

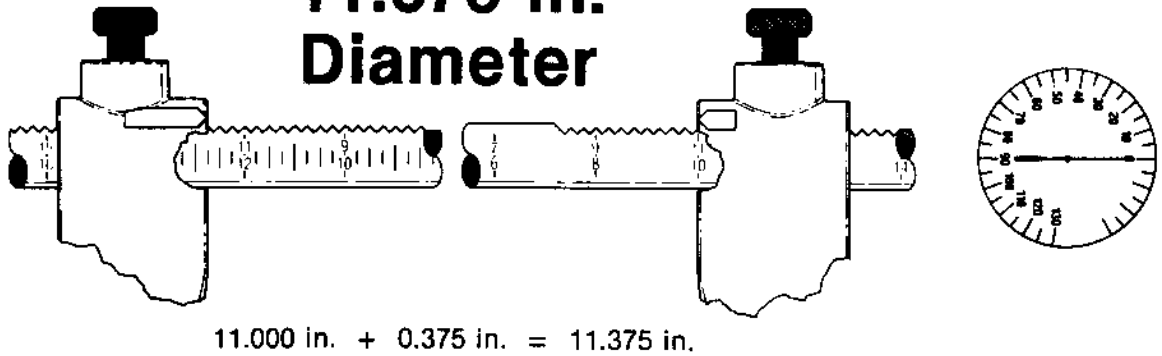

**11.390 in.
Diameter**

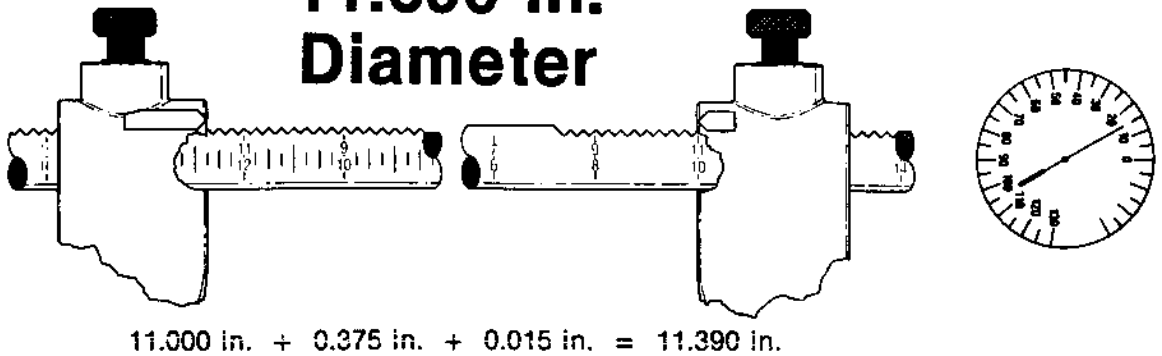

PANZITTA SALES & SERVICE
72 George Avenue
Wilkes-Barre, PA 18705
570-822-6720 800-822-6720
www.panzittasales.com

METRIC

**27.00 cm
Diameter**

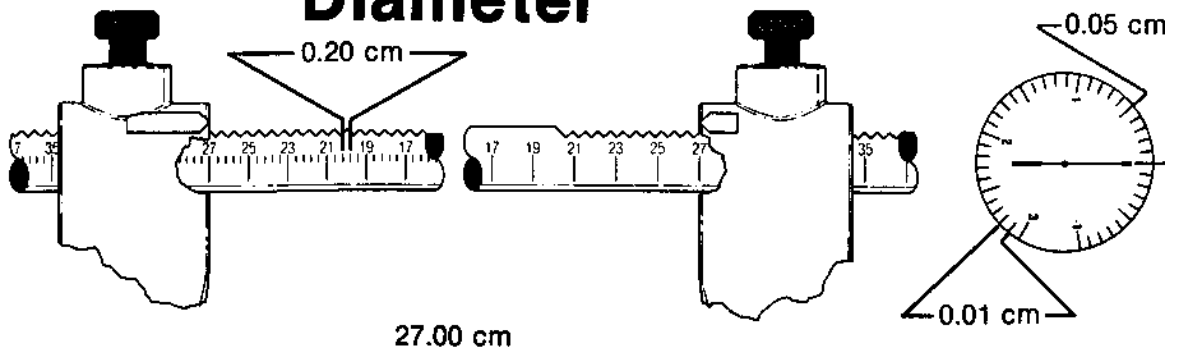

REPAIR KIT INCLUDES ASTERISKED PARTS

— order No. 26498
Repair Kit

29935

PANZITTA SALES & SERVICE
72 GEORGE AVE
WILKES-BARRE, PA 18705
570-822-6720 800-822-6720
www.panzittasales.com

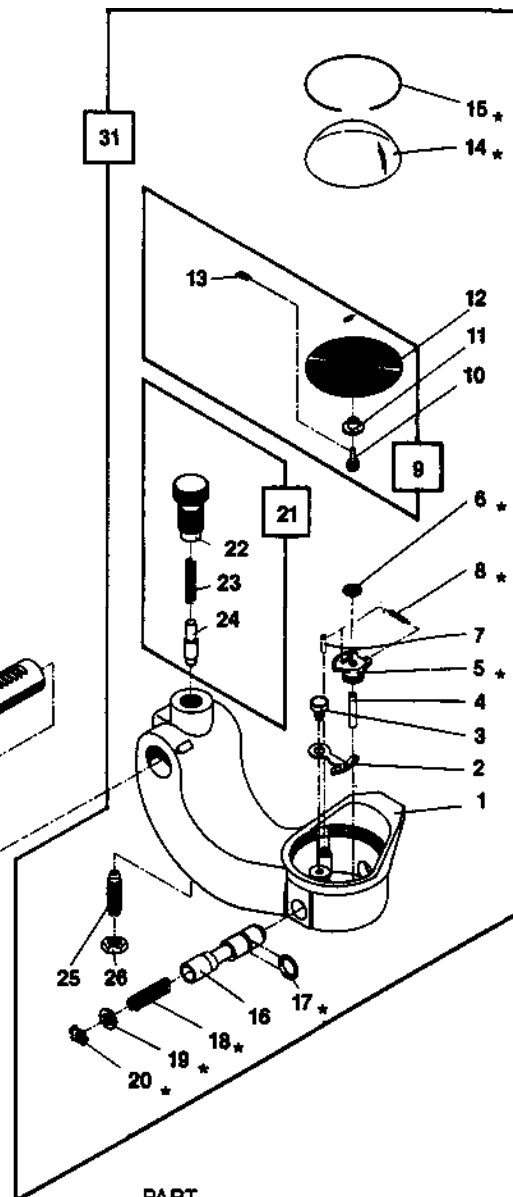
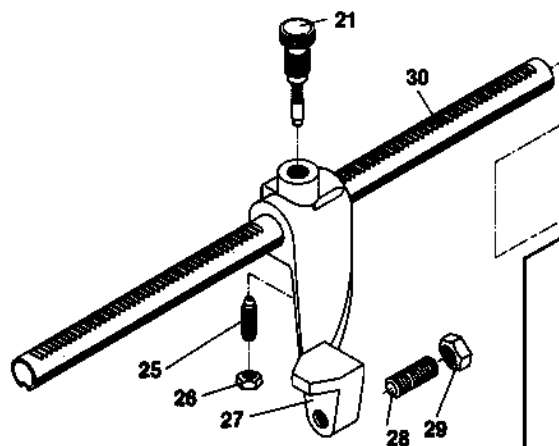

ITEM	PART NO.	QTY.	DESCRIPTION
1	8515	1	Indicator Body
2	8519	1	Driving Gear Segment
3	8520	1	Shoulder Stud
4	9480	1	Dowel Pin
5	*9968	1	Intermediate Pinion & Gear
6	*6845	1	Retaining Ring
7	6423	1	Groove Pin
8	*8521	1	Backlash Spring
9	8507	1	Inch Dial Assembly
9	8508	1	Metric Dial Assembly
10	8526	1	Pointer Pinion
11	8525	1	Pointer Shaft Bushing
12	8524	1	Inch Dial
12	8540	1	Metric Dial
13	8527	1	Pointer
14	*8528	1	Crystal
15	*8529	1	Retaining Ring
16	8518	1	Plunger
17	*6138	1	Retaining Ring
18	*8517	1	Plunger Spring

ITEM	PART NO.	QTY.	DESCRIPTION
19	*8516	1	Plug
20	*6140	1	Retaining Ring
21	9994	2	Plunger Screw Assembly
22	9984	2	Plunger Screw
23	3529	2	Plunger Lockscrew Spring
24	10295	2	Plunger Lock
25	9879	2	Locating Screw
26	3528	2	1/4"-20 Hex Jam Nut
27	8530	1	Anvil Arm
28	6844	1	3/8"-24 x 1" Hex. Soc. Hd. Screw
29	6509	1	3/8"-24 Hex. Jam Nut
30	8531	1	Inch Graduated Shaft 6"-16-1/8"
30	8539	0	Optional Inch Graduated Shaft 16"-26"
30	8541	1	Metric Graduated Shaft 15 cm-41 cm
30	8539-50	0	Optional Metric Graduated Sh 39 cm-66 cm
31	8502	1	Dial Base Assembly